

Flue Gas Desulfurization (FGD)

MIXERS



A World Leader In Industrial Mixing Since 1923. Lightnin has 90 years of unrivaled experience in industrial mixing technology, process knowledge, and technological innovation. Lightnin enjoys a global reputation for durable, long-lasting mixers, agitators, aerators, and flocculators for fluid process systems. We offer a full spectrum of impeller designs for diverse applications. In addition, we offer a worldwide service network, mixer repair, gearbox repair, and replacement parts programs. Look to Lightnin for knowledge, technology and service excellence.

Based in Charlotte, North Carolina, SPX Corporation (NYSE: SPW) is a global Fortune 500 multi-industry manufacturing leader with over \$5 billion in annual revenue, operations in more than 35 countries and over 15,000 employees. The company's highly-specialized, engineered products and technologies are concentrated in Flow Technology and energy infrastructure. Many of SPX's innovative solutions are playing a role in helping to meet rising global demand for electricity and processed foods and beverages, particularly in emerging markets. The company's products include food processing systems for the food and beverage industry, power transformers for utility companies, and cooling systems for power plants. For more information, please visit www.spx.com.

Like your FGD process, your mixing equipment is an investment for the future

Lightnin has successfully applied hundreds of Top and Side Entry agitators for flue gas desulfurization processes, from the very first FGD installation in the 1960's at the Lawrence Energy Center to today's modern power plants. Since the first installation, the Boiler Systems have advanced considerably from the multiple Absorber Towers per Boiler in the 1970's and 80's to today's systems with a single tower per Boiler, capable of operation for extended periods without shutdown. At Lightnin, we bring 90 years of mixing experience to your flue gas desulfurization (FGD) process. We believe that getting the job done right means providing the degree of mixing you need while striking the best balance of capital cost, energy consumption, and reliability.

MODERN TESTING COMPUTATIONAL FLUID DYNAMICS: A PRECISE, COMPREHENSIVE LOOK AT YOUR MIXING PROCESS

The Lightnin Process & Technology Laboratory is fully equipped to model test any mixing portion of the FGD process. All FGD unit operations, from liquid-solid (solids suspension and re-suspension) to gas-liquid-solid (gas dispersion and mass transfer), can be analyzed to evaluate agitator performance.

A Computational Fluid Dynamics (CFD) modeling program is used to analyze agitator performance in the full-scale installation.

The CFD software program models the combined dynamic effects of the agitator design, vessel geometry, pump inlets, and suction and slurry characteristics.

TESTING SCALE-UP (AND SCALE-DOWN)

Correlating a small-scale mixing system to a large system is a complicated procedure. From Lightnin's years of mixing experience, we're well prepared to scale up, or scale down, accurately. Adding gas to a slurry not only complicates the process requirements of an agitator, it complicates the scaling procedure as well. At Lightnin, we can scale gas dispersion and mass transfer applications - both to evaluate full-scale performance and to determine how to improve your particular FGD forced oxidation process.



THEORY OF OPERATION:

VSF Side-Entry Mixer Designed for FGD Absorber Service

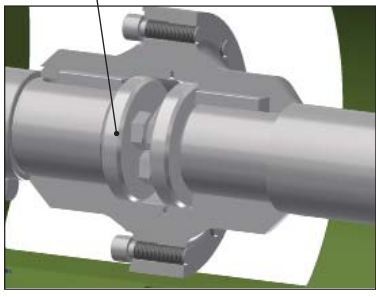
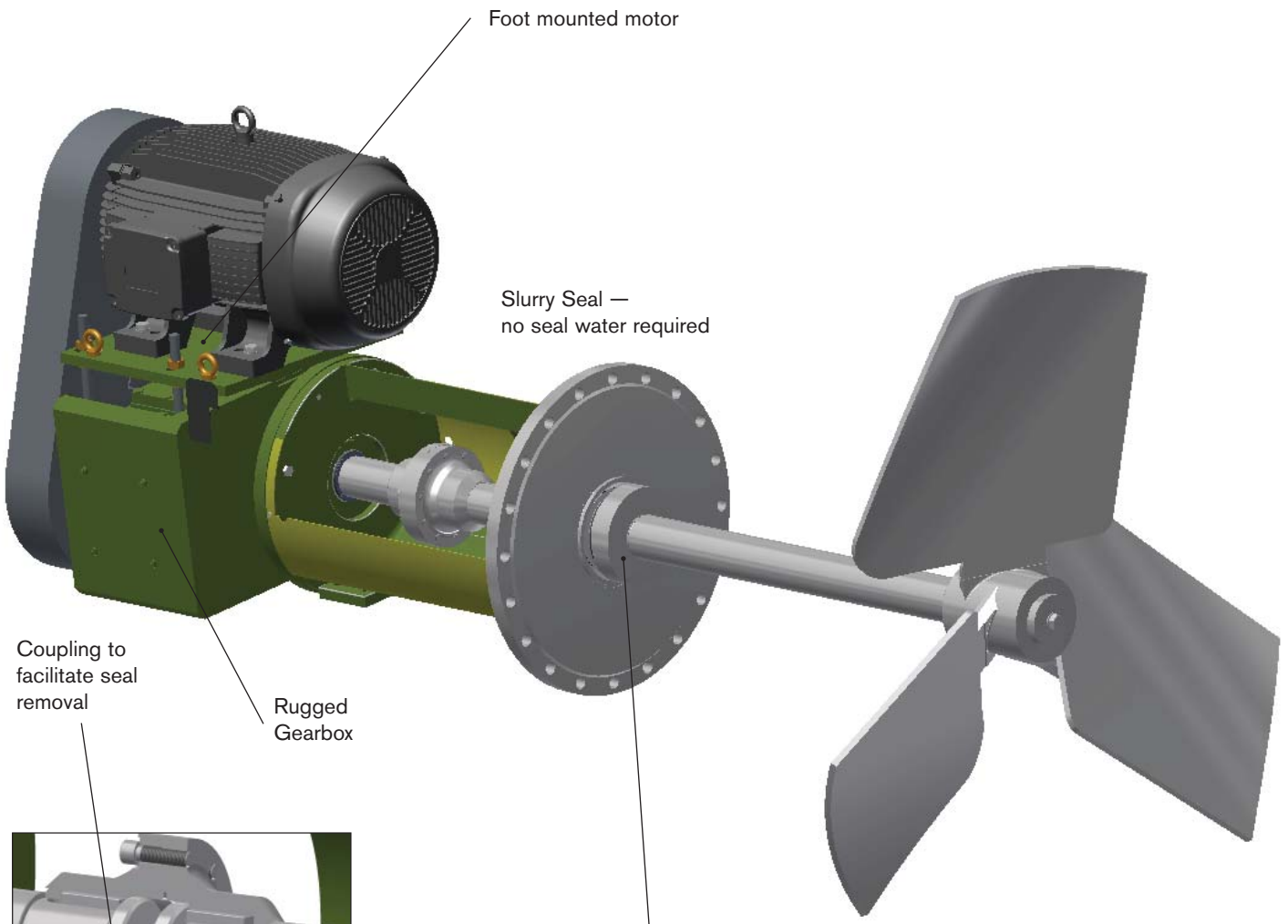

Belt drive unit also available.

Seal shutoff to provide maintenance on unit while Absorber is in operation.

Impeller hub is sealed to prevent ingress of slurry and subsequent corrosion and localized pitting. Multiple o-rings allow easy assembly and disassembly for maintenance.

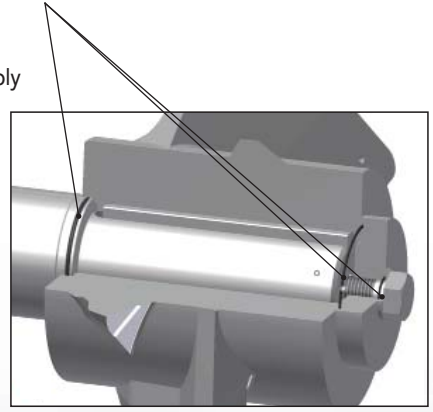

The Lightnin FGD Single Slurry Seal

Mechanical seal designed to excel in a harsh FGD environment. Engineered to operate with no outside flush liquid to reduce your operating expenses, dependency and usage of plant water.

Carbide faces, resistant to abrasion, geometry is designed for slurries

Integrated shutoff, easy to operate and contain tank contents while changing the seal

Low pressure clean out, recommended use before startup and shutdown

Sleeve drive attaches without burring the agitator shaft

Shroud protects pins and springs from the process

Duplex stainless wetted metal for high chloride FGD service

Sleeve centering tabs to ensure seal is properly installed

Radial bearing to minimize deflection and increase seal life

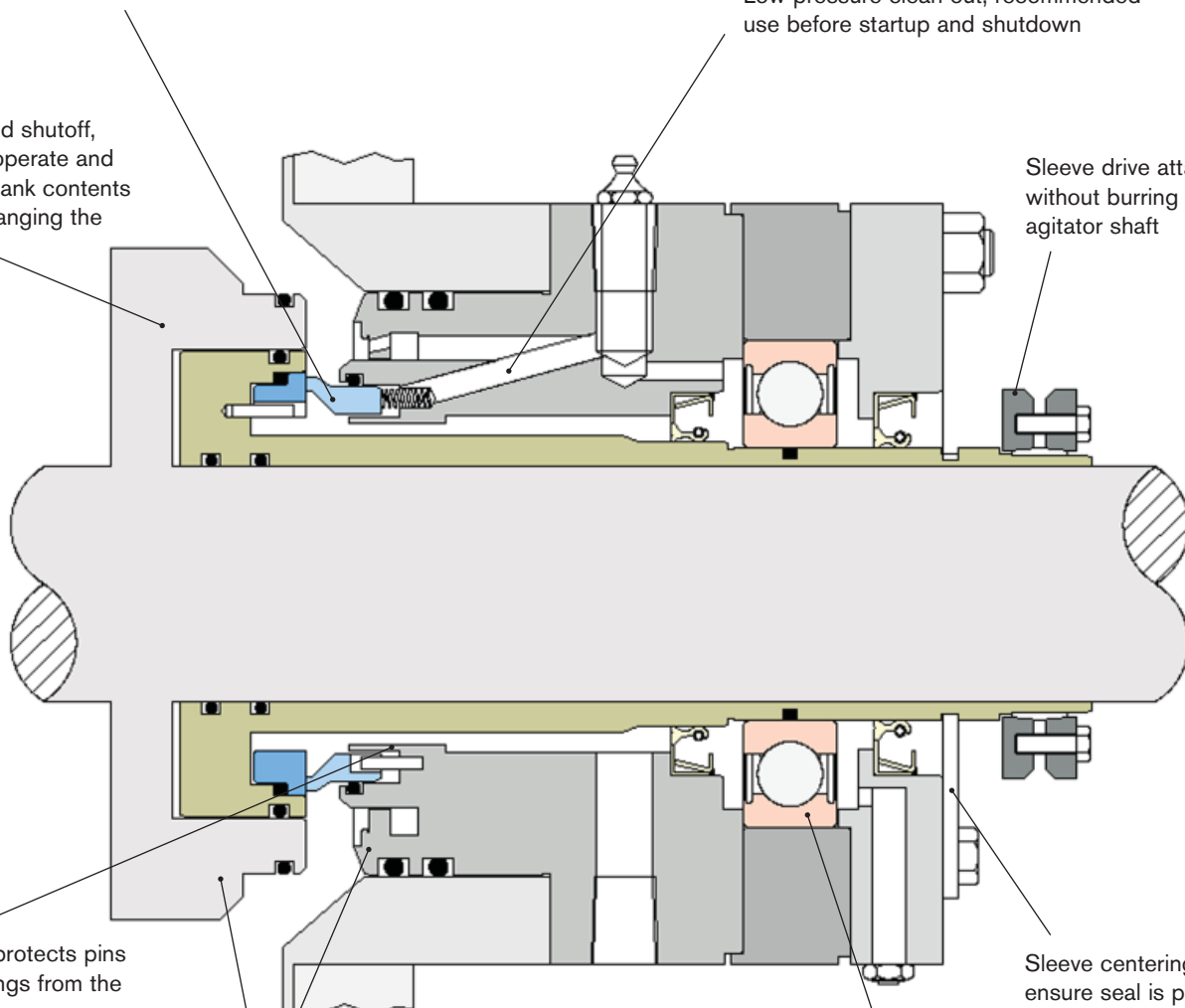

OXIDATION LANCE SYSTEM

FGD Systems have evolved to Forced Oxidation with a Lance designed to feed the proper amount of Oxidation Air into the Absorber Vessel and achieve the desired Mass Transfer.

Lightnin has extensive experience in designing and supplying Gas Sparge Systems for Mass Transfer in many different markets and applications. Specifically for FGD, Lightnin developed a lance sparge system to provide the required mass transfer in an FGD Absorber. Supplied initially to Endesa's Compostilla Power Plant in Ponferrada, Leon, Spain, Lightnin's Lance technology has proven successful in many installations throughout Europe and China. Lightnin's expertise and understanding of Mass Transfer phenomena allows Scrubber suppliers and Utilities to optimize their oxidation systems for maximum efficiency.

The Lightnin VSF Side-Entering Mixer with A-312 Impeller

A-312 Impeller: This hydrofoil impeller is specifically designed for the requirements of flue gas desulfurization. The impeller generates a strong, focused discharge across the swept diameter that ensures good solid suspension and gas dispersion. The optimum blade configuration also eliminates the formation of eddy currents on the trailing surface of the blade. This design feature greatly reduces erosion and increases blade life.



Lightnin VSF Side Entry Mixer



A-312 Impeller



For Rugged, Reliable Service, Lightnin Mixers Clean Up.

Lightnin mixers set industry standards for performance and durability. Our integrated mixer design means that shaft systems and impellers are accurately matched to provide years of dependable operation. We also manufacture our own speed reducers developed specifically for industrial mixer service.

Lightnin “Workhorse” Series 70 Mixers

Deliver up to 1250 hp/932 KW. These mixers are built to handle the severe duty of solids suspension and re-suspension, blending and gas dispersion.

The Lightnin A510/A310 Impeller Cuts Power Consumption By Up to 50%

From Lightnin's laser lab came the A510/A310 family of impellers — high-efficiency designs that handle all requirements of the FGD process. For solids suspension, the A510/A310, and its side-entry version, the A312, are specifically designed to generate high flow per power.

The A510 impeller system, with its varying angle options, can optimize processes by changing its shear characteristics or impeller/tank diameter ratio. In fact, the A510/A310/A312 impeller designs cut power consumption when compared to traditional pitched-blade turbines and propellers. These high-efficiency impellers generate a near-constant flow velocity (and therefore low shear) across the swept diameter.

This optimum blade design also eliminates the formation of the undesirable eddy currents on the trailing surface of the blade. In the case of abrasive FGD slurries, these currents will erode metal and rubber coated impeller surfaces.



Series 70 Mixer



A510/A310 Impeller



Flue gas desulfurization (FGD) is a set of technologies used to remove sulfur dioxide (SO₂) from exhaust flue gases of fossil-fuel power plants, and from the emissions of other sulfur oxide emitting processes.



Flue Gas Desulfurization {FGD}

MIXERS



EXPERT SALES AND SERVICE IS AVAILABLE AROUND THE WORLD

The worldwide Lightnin organization stands ready to spec, quote, and service all your mixers applications in flue gas desulfurization. On a global basis, strategically located Lightnin manufacturing and service facilities make equipment delivery and after-order service fast and dependable. Our dedicated global service teams are readily available to support your process equipment. Genuine spare parts and service solutions can be obtained from locations around the world and ensure operating capacity of your valuable production equipment.

SERVICE

SPX Flow Technology Services

- Equipment Services
- PM/PDM Services
- Additional Services
- Installation and Startup
- Maintenance and Repair

CALL THE SPX EXPERTS

For more information about the Lightnin FGD/VSF Mixers or to discuss your application, contact your local SPX Flow Technology Sales Office Representative. Or visit our website at www.spx.com/en/lightnin

Global locations

USA

SPX GLOBAL HEADQUARTERS

13320 Ballantyne Corporate Place
Charlotte, NC 28277
United States of America
+1 704 752 4400

APAC

SPX ASIA PACIFIC

2F, Treasury Building
1568 Hua Shan Road
Shanghai 20000523
Peoples Republic of China
+86 21 2208 5888

INDIA

SPX FLOW TECHNOLOGY INDIA

Survey No. 275
Odhav Road
Odhav
Ahmedabad 382415
+91 (0) 79 2287 0311

EMEA

SPX EUROPE

Ocean House
Towers Business Park
Wilmslow Road
Manchester, M20 2LY England
+44 (0) 161 2491170

SPX FLOW TECHNOLOGY

135 Mt. Read Blvd.
Rochester, NY 14611
P: (888) 649-2378 (MIX-BEST), US and Canada) or +1 (585) 436-5550
F: (585) 436-5589
E: lightnin@spx.com ▪ www.spx.com/en/lightnin

For other Sales locations click
<http://www.spx.com/en/lightnin/where-to-buy/>
or use your SmartPhone and the QR Code



SPX reserves the right to incorporate our latest design and material changes without notice or obligation.

Design features, materials of construction and dimensional data, as described in this bulletin, are provided for your information only and should not be relied upon unless confirmed in writing. Please contact your local sales representative for product availability in your region. For more information visit www.spx.com.

The green ">" is a trademark of SPX Corporation, Inc.

ISSUED 08/2013 B-922

COPYRIGHT © 2013 SPX Corporation